

COMMONLY SERVICED COMPONENTS

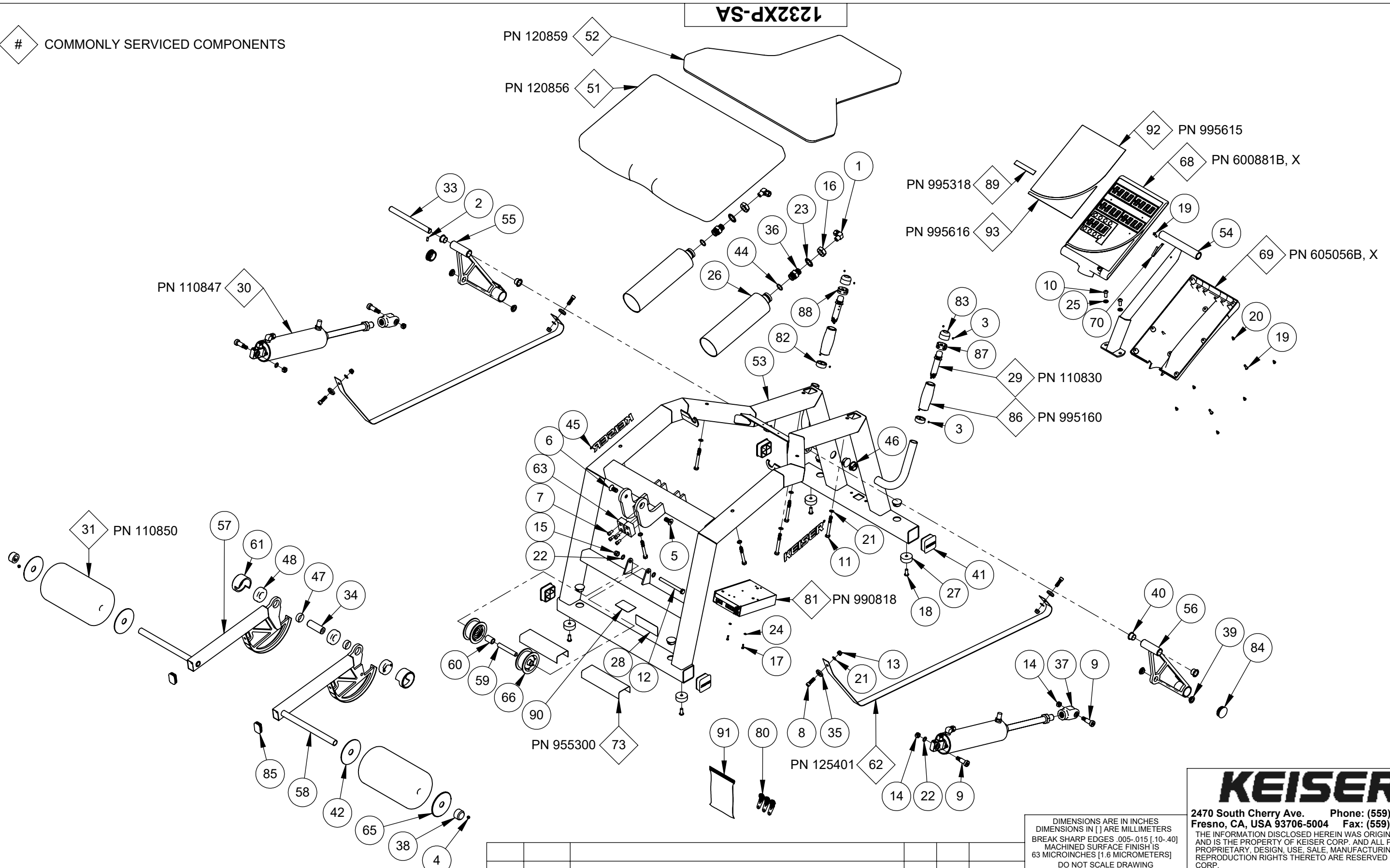

NOTE:

1232XP-SA COVERS THE FOLLOWING MODELS: 1232BP AND 1232XP

REV	ECO	REVISION DESCRIPTION	BY	CKD	DATE
A	3807	RFP	BJU	LC	3/23/21

DIMENSIONS ARE IN INCHES
DIMENSIONS IN [] ARE MILLIMETERS
BREAK SHARP EDGES .005-.015 [.10-.40]
MACHINED SURFACE FINISH IS
63 MICROINCHES [1.6 MICROMETERS]
DO NOT SCALE DRAWING

KEISER[®]
2470 South Cherry Ave. Phone: (559) 256-8000
Fresno, CA, USA 93706-5004 Fax: (559) 256-8100
THE INFORMATION DISCLOSED HEREIN WAS ORIGINATED BY
AND IS THE PROPERTY OF KEISER CORP. AND ALL PATENT,
PROPRIETARY, DESIGN, USE, SALE, MANUFACTURING, AND
REPRODUCTION RIGHTS THERETO ARE RESERVED BY KEISER
CORP.

DRAWN BY: BJU	DATE DRAWN: 11/09/20	CHECKED BY: LC	DATE CHECKED: 3/23/21
MATERIAL:		RAW MAT:	
TITLE: A300 LEG CURL PRO - PWR-SA		SCALE: 1:12	
SHEET 1 OF 2		DRAWING SIZE: B	
PART#: 1232XP-SA		MASS (Kg):	

X:\drawings\REVISION\12_LEG_CURL\ PRINTED ON: 3/25/2021 SW2006 V5.1

ITEM NO.	QTY.	PART NO.	TITLE	ITEM NO.	QTY.	PART NO.	TITLE
1	2	8153	CAF - ME-3/8 C X 1/4 M	64	1	170891	ASSY - MUFFLER-LONG
2	1	9001	PIN SPRING - 3/16 X 1/2	65	2	265055	BEVEL WASHER
3	8	9014	SCREW - HSSS 8-32 X 1/8 SS	66	2	265419	BELT PULLEY
4	2	9026	SCREW - HSSS 5/16-18 X 1/4 ZP	67	1	320800	VALVE BLOCK
5	1	9076	SCREW - SFCHCS 04375-14 X 1 ZP	68	1	600881	DISPLAY BOX 5 - WIN
6	1	9077	SCREW - SFCHCS SL 04375-14 X 1 BLK	69	1	605056	DISPLAY BOX - BACK-CS
7	4	9098	SCREW - SHCS 1/4-20 X 1/2 ZP	70	1	605428	GROUND CLAMP - DISPLAY
8	4	9101	SCREW - SHCS 5/16-18 X 1 ZP	71	1	953101	TUBING - .375 OD X .062 W-PE BLK
9	4	9127	SCREW - SHSS 1/2 X 1 ZP	72	1	953108	TUBING - 1/4 URETHANE BLK
10	2	9135	SCREW - SBHCS 5/16-18 X 3/4 ZP	73	1	955300	STRIP - PROTECTOR-4 INCH
11	6	9181	SCREW - HHCS 5/16-18 X 2 3/4 ZP	74	2	962004	CON - 2MM-2-S
12	1	9211	SCREW - HHCS 3/8-16 X 4 ZP	75	6	962005	CON - MOD-P-4P-4C
13	4	9226	NUT - HELN 5/16-18 ZP	76	1	962016	CON - MOD-COUPLER-6-6
14	4	9227	NUT - HRLN 3/8-16 ZP	77	4	962017	CON - MOD-P-6P-6C
15	1	9228	NUT - HELN 3/8-16 ZP	78	1	966701	WIRE - CABLE-4-26 GA
16	2	9231	NUT - HJN 3/4-10 ZP	79	1	966702	WIRE - CABLE-6-26 GA
17	2	9272	SCREW - CRPHTS-TF #6-32 X 1/2 SS	80	3	990812	KEY - DATA-CS
18	4	9279	SCREW - SBHTS-TF 5/16-18 X 3/4 ZP	81	1	990818	PROCESSOR BOX - A250-DBL
19	3	9285	SCREW - CRPHTS 10-24 X 3/4 ZP	82	2	995000	COLLAR - GRIP
20	6	9291	SCREW - CRPHTS 8 X 1/2 ZP	83	2	995001	CAP - GRIP W HOLE
21	10	9353	WASHER - ACFT-5/16 ZP	84	2	995060	PLUG - TUBE-1500 OD
22	4	9355	WASHER - FW-ACFT-3/8 SS	85	2	995061	PLUG - TUBE-1000 X 1500
23	2	9364	WASHER - ITLW 3/4 ZP	86	2	995160	GRIP - MOLDED
24	2	9366	WASHER - ITLW #6 ZP	87	1	995300	DECAL - TB-PLUS
25	2	9389	WASHER - ITLW 5/16 ZP	88	1	995301	DECAL - TB-MINUS
26	2	100903	TANK - 72 IN3	89	1	995318	DECAL - NO ADJ-POWER
27	4	105423	BUMPER - MOLDED GLIDE	90	1	995324	DECAL - MADE IN THE USA
28	1	105443	DECAL - SERIAL NUMBER	91	1	995418	BAG - 4 X 6 X 4MIL-ZIP LOCK
29	2	110830	ASSY - TB VALVE-DIG	92	1	995615	PLACARD - ENG-POWER-BLK
30	2	110847	ASSY - EC-2.5 X 7	93	1	995616	PLACARD - ENG-KEY-RED
31	2	110850	ROLLER CUSHION				
32	1	110897	ASSY - QD-MALE				
33	1	112180	SHAFT - PUSH ARM				
34	1	112221	PIVOT SHAFT				
35	4	112242	CLAMP DISC				
36	2	115000	BUSHING - TANK				
37	2	115005	CLEVIS - CYLINDER-2-1/2				
38	2	115006	3/4 END CAP				
39	4	115051	BEARING - FLANGE-.5 ID				
40	4	115052	BEARING - FLANGE-.625 ID				
41	4	115054	PLUG - 2 IN SQ-KEISER				
42	2	115055	WASHER - UPHOLSTERY ROLLER				
43	1	115323	FILTER - IN LINE				
44	2	115333	O-RING - .943 X .737 X .103				
45	2	115372	DECAL - KEISER LOGO-1 1/4" RED				
46	6	115404	PLUG - HOLE-1 DIA				
47	2	115420	NEEDLE BEARING B-146				
48	3	115421	THRUST BEARING T-88				
49	14	115423	TIE - 8 IN-PL BLK				
50	1	115429	PLASTIC TIE - 10" RED				
51	1	120856	SHORT CUSHION				
52	1	120859	LONG CUSHION - LC PRO				
53	1	120925	MAIN FRAME - LC PRO				
54	1	120926	DISPLAY MT - LC PRO				
55	1	120927	LEVER ARM - L				
56	1	120928	LEVER ARM - R				
57	1	120929	EXERCISE ARM - L				
58	1	120930	EXERCISE ARM - R				
59	1	123040	TUBE - BELT PULLEY				
60	1	123070	TUBE - PULLEY SPACER				
61	2	125060	COVER - BEARING-WIDE				
62	2	125401	BELT - LC PRO				
63	2	165421	STOP - EA-URETHANE				

1232XP-SA

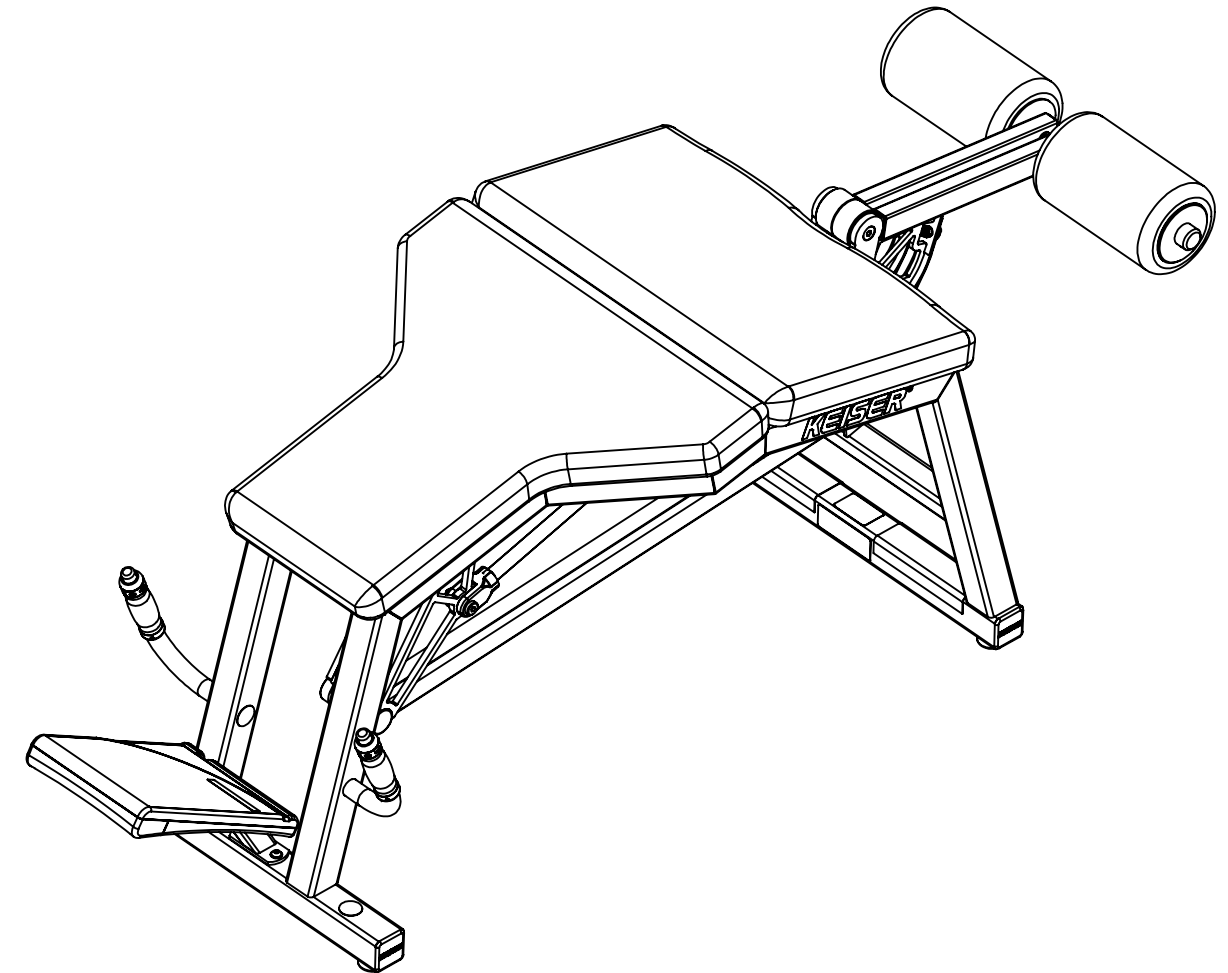

PRINTED ON: 3/25/2021 SW2006 V5.1

X:\drawings\REVISION\12_LEG_CURL

KEISER[®]

2470 South Cherry Ave. Phone: (559) 256-8000
 Fresno, CA, USA 93706-5004 Fax: (559) 256-8100

THE INFORMATION DISCLOSED HEREIN WAS ORIGINATED BY AND IS THE PROPERTY OF KEISER CORP. AND ALL PATENT, PROPRIETARY, DESIGN, USE, SALE, MANUFACTURING, AND REPRODUCTION RIGHTS THERETO ARE RESERVED BY KEISER CORP.

DIMENSIONS ARE IN INCHES
 DIMENSIONS IN [] ARE MILLIMETERS
 BREAK SHARP EDGES .005-.015 [.10-.40]
 MACHINED SURFACE FINISH IS
 63 MICROINCHES [1.6 MICROMETERS]
 DO NOT SCALE DRAWING

DRAWN BY: BJU	DATE DRAWN: 11/09/20	CHECKED BY: LC	DATE CHECKED: 3/23/21
---------------	----------------------	----------------	-----------------------

MATERIAL: _____
 RAW MAT: _____
 MASS (Kg): _____

TITLE: **A300 LEG CURL PRO - PWR-SA**

SHEET **2** OF **2** SCALE: **1:10** DRAWING SIZE: **B** PART#: **1232XP-SA**

REV	ECO	RFP	BY	CKD	DATE
A	3807	RFP	BJU	LC	3/23/21