

2821XP-SA

COMMONLY SERVICED COMPONENTS

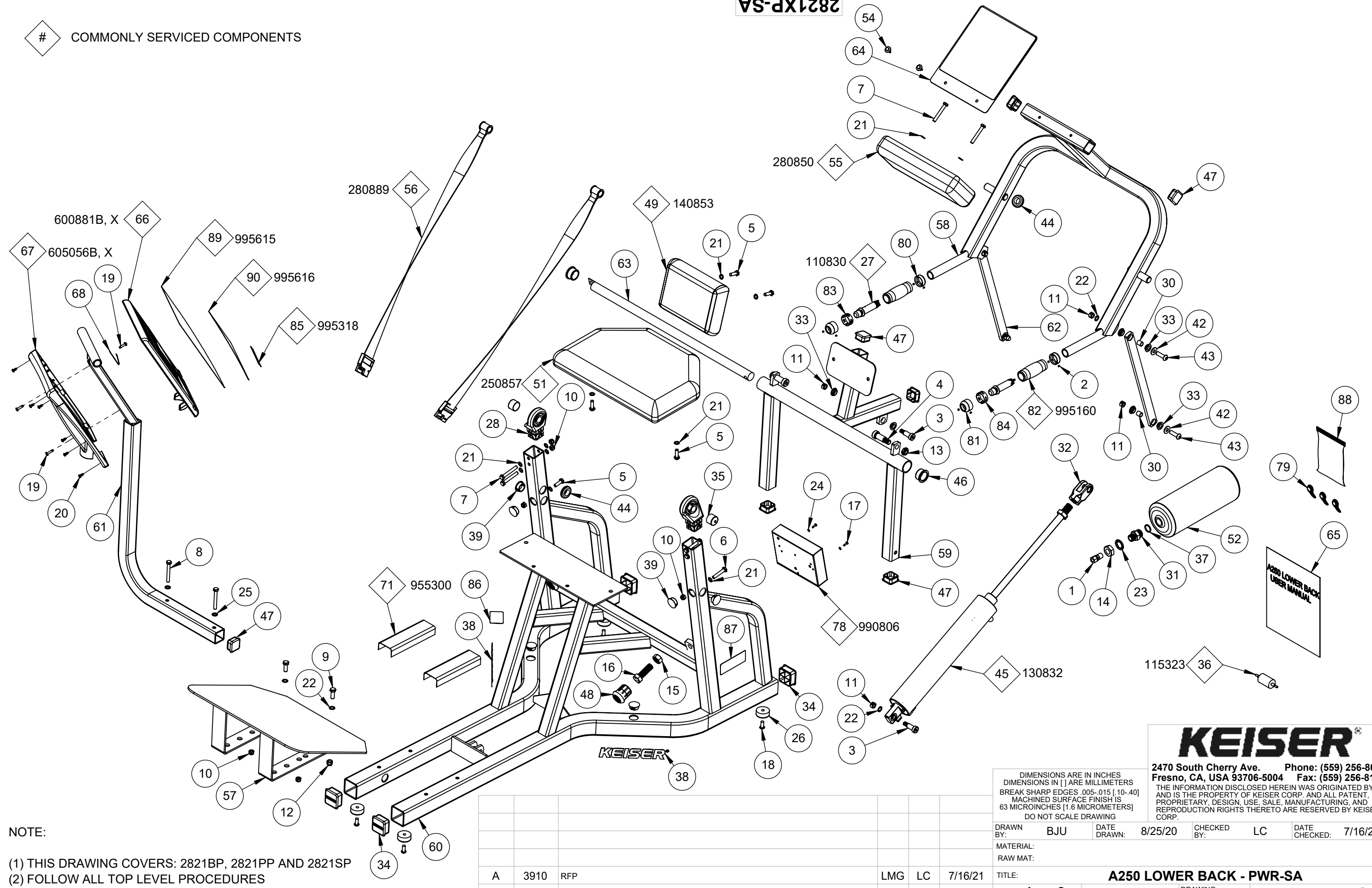

NOTE:
 (1) THIS DRAWING COVERS: 2821BP, 2821PP AND 2821SP
 (2) FOLLOW ALL TOP LEVEL PROCEDURES

| REV | ECO | RFP | REVISION DESCRIPTION | BY | CKD | DATE |
|-----|------|-----|----------------------|-----|-----|---------|
| A | 3910 | RFP | | LMG | LC | 7/16/21 |

DIMENSIONS ARE IN INCHES
 DIMENSIONS IN [] ARE MILLIMETERS
 BREAK SHARP EDGES .005-.015 [.10-.40]
 MACHINED SURFACE FINISH IS
 63 MICRONS [1.6 MICROMETERS]
 DO NOT SCALE DRAWING

| | | | |
|--------------------|---------------------|----------------|--------------------------------|
| DRAWN BY: BJU | DATE DRAWN: 8/25/20 | CHECKED BY: LC | DATE CHECKED: 7/16/21 |
| MATERIAL: RAW MAT: | | | |
| SHEET 1 OF 2 | | SCALE: 1:20 | DRAWING SIZE: PART#: 2821XP-SA |

KEISER[®]
 2470 South Cherry Ave. Phone: (559) 256-8000
 Fresno, CA, USA 93706-5004 Fax: (559) 256-8100
 THE INFORMATION DISCLOSED HEREIN WAS ORIGINATED BY AND IS THE PROPERTY OF KEISER CORP. AND ALL PATENT, PROPRIETARY, DESIGN, USE, SALE, MANUFACTURING, AND REPRODUCTION RIGHTS THERE TO ARE RESERVED BY KEISER CORP.

X:\drawings\REVISION\28_LOWER_BACK\ PRINTED ON: 7/16/2021 SW2006 V5.1

| ITEM NO. | QTY. | PART NO. | TITLE | ITEM NO. | QTY. | PART NO. | TITLE |
|----------|------|----------|-----------------------------------|----------|------|----------|----------------------------------|
| 1 | 1 | 8079 | CON - 3/8C X 1/4M | 64 | 1 | 285416 | PLACARD - A250 LOWER BACK |
| 2 | 8 | 9014 | SCREW - HSSS 8-32 X 1/8 SS | 65 | 1 | 285501 | MANUAL - USER - A250 LOWER BACK |
| 3 | 2 | 9127 | SCREW - SHSS 1/2 X 1 ZP | 66 | 1 | 600881X | DISPLAY BOX - 5 WIN |
| 4 | 2 | 9128 | SCREW - SHSS 5/8 X 1-1/4 ZP | 67 | 1 | 605056 | DISPLAY BOX - BACK |
| 5 | 5 | 9176 | SCREW - HHCS 5/16-18 X 1 ZP | 68 | 1 | 605428 | GROUND CLAMP - DISPLAY |
| 6 | 1 | 9177 | SCREW - HHCS 5/16-18 X 1-3/4 ZP | 69 | 1 | 953101 | TUBING - .375 OD X .062 W-PE BLK |
| 7 | 6 | 9179 | SCREW - HHCS 5/16-18 X 2-1/4 ZP | 70 | 1 | 953108 | TUBING - 1/4 URETHANE BLK |
| 8 | 2 | 9180 | SCREW - HHCS 5/16-18 X 2-1/2 ZP | 71 | 2 | 955300 | STRIP - PROTECTOR-4 INCH |
| 9 | 2 | 9201 | SCREW - HHCS 3/8-16 X 1 ZP | 72 | 2 | 962004 | CON - 2MM-2-S |
| 10 | 8 | 9226 | NUT - HELN 5/16-18 ZP | 73 | 4 | 962005 | CON - MOD - P-4P-4C |
| 11 | 6 | 9227 | NUT - HRLN 3/8-16 ZP | 74 | 1 | 962016 | CON - MOD-COUPLER-6-6 |
| 12 | 2 | 9228 | NUT - HELN 3/8-16 ZP | 75 | 4 | 962017 | CON-MOD-P-6P-6C |
| 13 | 2 | 9230 | NUT - HELN 1/2-13 ZP | 76 | 1 | 966701 | WIRE - CABLE-4-26 GA |
| 14 | 1 | 9231 | NUT - HJN 3/4-10 ZP | 77 | 1 | 966702 | WIRE - CABLE-6-26 GA |
| 15 | 2 | 9232 | NUT - HN 5/8-18 NF ZP | 78 | 1 | 990806 | ASSY - PROCESSOR BOX |
| 16 | 2 | 9251 | SCREW - HHCS 5/8-18 X 2 ZP | 79 | 3 | 990812 | KEY - DATA-CS |
| 17 | 2 | 9272 | SCREW - CRPHTS-TF #6-32 X 1/2 SS | 80 | 2 | 995000 | COLLAR - GRIP |
| 18 | 4 | 9279 | SCREW - SBHTS-TF 5/16-18 X 3/4 ZP | 81 | 2 | 995001 | CAP - GRIP W HOLE |
| 19 | 3 | 9285 | SCREW - CRPHTS 10-24 X 3/4 ZP | 82 | 2 | 995160 | GRIP - MOLDED |
| 20 | 6 | 9291 | SCREW - CRPHTS 8 X 1/2 ZP | 83 | 1 | 995300 | DECAL - TB-PLUS |
| 21 | 16 | 9353 | WASHER - ACFT-5/16 ZP | 84 | 1 | 995301 | DECAL - TB-MINUS |
| 22 | 5 | 9355 | WASHER - FW-ACFT-3/8 SS | 85 | 1 | 995318 | DECAL - NO ADJ-POWER |
| 23 | 1 | 9364 | WASHER - ITLW 3/4 ZP | 86 | 1 | 995324 | DECAL - MADE IN THE USA |
| 24 | 2 | 9366 | WASHER - ITLW #6 ZP | 87 | 1 | 995381 | DECAL - SERIAL NUMBER - STRENGTH |
| 25 | 2 | 9389 | WASHER - ITLW 5/16 ZP | 88 | 1 | 995418 | BAG - 4 X 6 X 4MIL-ZIP LOCK |
| 26 | 4 | 105423 | BUMPER - MOLDED GLIDE | 89 | 1 | 995615 | PLACARD - ENG-POWER-BLK |
| 27 | 2 | 110830 | ASSY - TB VALVE-DIG | 90 | 1 | 995616 | PLACARD - ENG-KEY-RED |
| 28 | 2 | 110894 | BEARING ASSY | | | | |
| 29 | 1 | 110897 | ASSY - QD-MALE | | | | |
| 30 | 4 | 113040 | SHOULDER SLEEVE - 1/2 X 1/2 | | | | |
| 31 | 1 | 115000 | BUSHING - TANK | | | | |
| 32 | 1 | 115005 | CLEVIS - CYLINDER-2-1/2 | | | | |
| 33 | 10 | 115051 | BEARING - FLANGE-.5 ID | | | | |
| 34 | 4 | 115054 | PLUG - 2 IN SQ-KEISER | | | | |
| 35 | 2 | 115067 | CAP - Ø1 X 3/4 | | | | |
| 36 | 1 | 115323 | FILTER - IN LINE | | | | |
| 37 | 1 | 115333 | O-RING - .943 X .737 X .103 | | | | |
| 38 | 2 | 115372 | DECAL - KEISER LOGO-1 1/4" RED | | | | |
| 39 | 6 | 115404 | PLUG - HOLE-1 DIA | | | | |
| 40 | 4 | 115423 | TIE - 8 IN-PL BLK | | | | |
| 41 | 1 | 115429 | PLASTIC TIE - 10" RED | | | | |
| 42 | 4 | 115450 | WASHER - FW .88 X .39 X .07 NP | | | | |
| 43 | 4 | 115451 | SCREW - SBHCS 3/8-16 X 1-1/4 NP | | | | |
| 44 | 2 | 115463 | GROMMET - 075106013 | | | | |
| 45 | 1 | 130832 | ASSY - EC-2.5 X 12 | | | | |
| 46 | 2 | 135050 | BEARING - FLANGE-1" ID | | | | |
| 47 | 7 | 135056 | CAP - 1.500 SQ-PL | | | | |
| 48 | 2 | 135422 | RUBBER CRUTCH TIP - #20 BLK | | | | |
| 49 | 1 | 140853 | ARM CUSHION | | | | |
| 50 | 1 | 170891 | ASSY - MUFFLER-LONG | | | | |
| 51 | 1 | 250857 | HEAD CUSHION | | | | |
| 52 | 1 | 255318 | TANK - 140 CU IN | | | | |
| 53 | 1 | 265310 | Y CONNECTOR - 1/8 DIA-PL | | | | |
| 54 | 2 | 265404 | PLASTIC RIVET | | | | |
| 55 | 1 | 280850 | BACK CUSHION | | | | |
| 56 | 1 | 280889 | SEAT BELT ASSY | | | | |
| 57 | 1 | 280904 | FOOT PLATE ASSY BLK | | | | |
| 58 | 1 | 280914 | EX ARM - A250 | | | | |
| 59 | 1 | 280915 | LEVER ARM BLK | | | | |
| 60 | 1 | 280917 | MAIN FRAME WHT | | | | |
| 61 | 1 | 280920 | WELDT - DISPLAY MT | | | | |
| 62 | 2 | 281881 | DRAG LINK BLK | | | | |
| 63 | 1 | 282241 | LEVER ARM - PIVOT SFT | | | | |

2821XP-SA

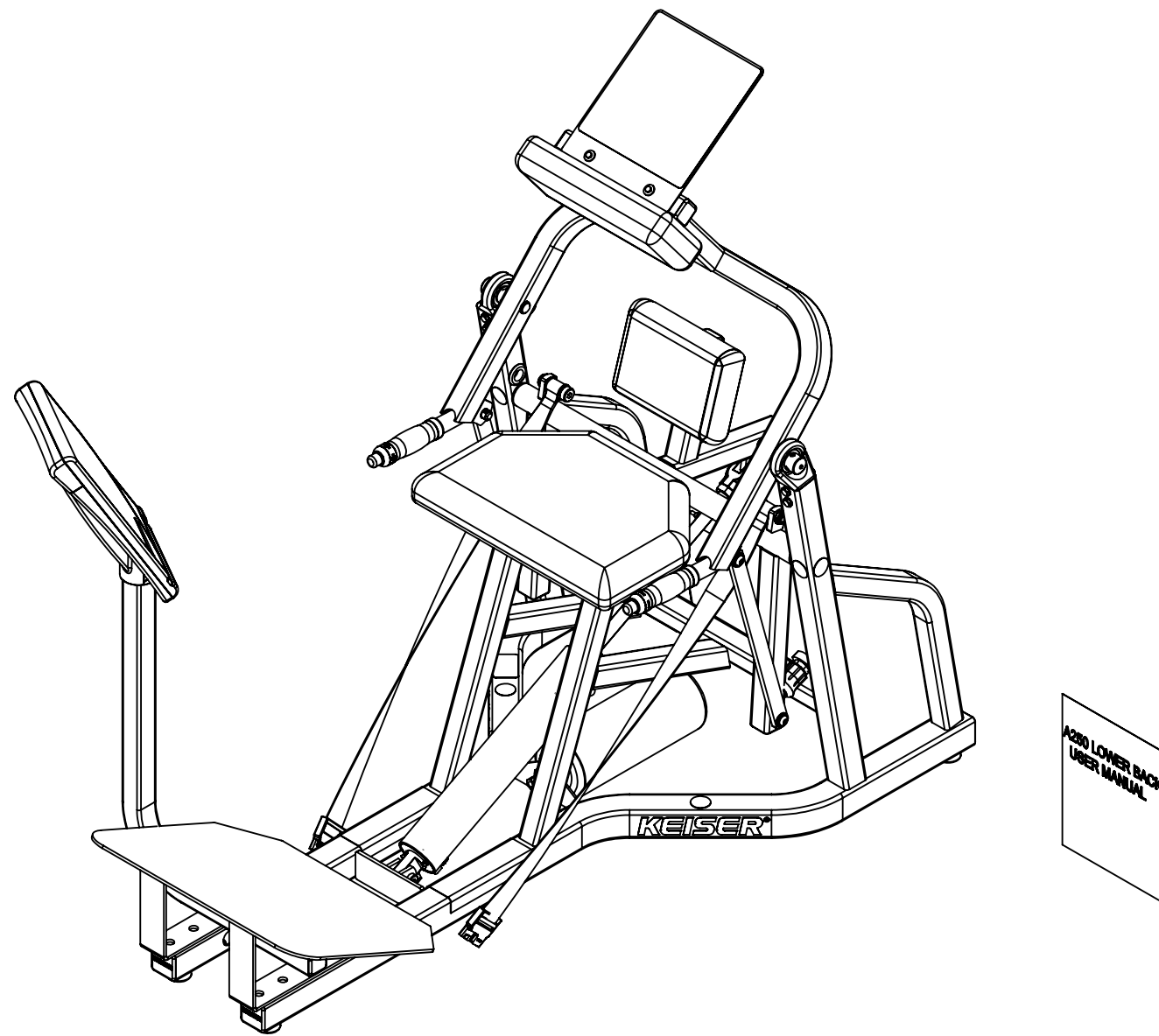

A250 LOWER BACK
USER MANUAL

KEISER®

2470 South Cherry Ave. Phone: (559) 256-8000
Fresno, CA, USA 93706-5004 Fax: (559) 256-8100

THE INFORMATION DISCLOSED HEREIN WAS ORIGINATED BY AND IS THE PROPERTY OF KEISER CORP. AND ALL PATENT, PROPRIETARY, DESIGN, USE, SALE, MANUFACTURING, AND REPRODUCTION RIGHTS THERETO ARE RESERVED BY KEISER CORP.

DIMENSIONS ARE IN INCHES
DIMENSIONS IN [] ARE MILLIMETERS
BREAK SHARP EDGES .005-.015 [.10-.40]
MACHINED SURFACE FINISH IS
63 MICROINCHES [1.6 MICROMETERS]
DO NOT SCALE DRAWING

DRAWN BY: BJU DATE DRAWN: 8/25/20 CHECKED BY: LC DATE CHECKED: 7/16/21

MATERIAL:
RAW MAT:

| REV | ECO | RFP | LMG | LC | 7/16/21 | TITLE: |
|-----|-----|-----|-----|----|---------|---|
| | | | | | | A250 LOWER BACK - PWR-SA |
| | | | | | | SHEET 2 OF 2 SCALE: 1:50 DRAWING SIZE: PART#: 2821XP-SA |
| | | | | | | REVISION DESCRIPTION BY CKD DATE |

PRINTED ON: 7/16/2021 SW2006 V5.1

X:\drawings\REVISION\28_LOWER_BACK\