

1133XP

NOTE:
 (1) 1133XP COVERS PN 1133BP AND 1133XP
 (2) SEE MEMO IN WINMAGI FOR FINISH SPECS

B	3648	RISW			JPR	DEM	10/5/20		
REV	ECO		REVISION DESCRIPTION		BY	CKD	DATE		

KEISER[®]

2470 South Cherry Ave. Phone: (559) 256-3000
 Fresno, CA, USA 93706-6004 Fax: (559) 256-8100

THE INFORMATION DISCLOSED HEREIN WAS ORIGINATED BY AND IS THE PROPERTY OF KEISER CORP. AND ALL PATENT, PROPRIETARY, DESIGN, USE, SALE, MANUFACTURING, AND REPRODUCTION RIGHTS THERE TO ARE RESERVED BY KEISER CORP.

DIMENSIONS ARE IN INCHES
 DIMENSIONS IN [] ARE MILLIMETERS
 BREAK SHARP EDGES .005-.015 [10-.40]
 MACHINED SURFACE FINISH IS
 63 MICRINCHES [1,6 MICROMETERS]
 DO NOT SCALE DRAWING

DRAWN BY: JPR DATE DRAWN: 10/8/18 CHECKED BY: DEM DATE CHECKED: 12/21/18
 MATERIAL: RAW MAT.

TITLE: **A-300 - LEG EXT PRO-PWR**

SHEET 1 OF 5 SCALE: 1:12 DRAWING SIZE: B PART#: 1133XP

X:\drawings\REVISION11_LEG_EXTENSION\ PRINTED ON: 10/6/2020 SW/2006 V5.1

ITEM NO.	QTY.	PART NO.	TITLE	ITEM NO.	QTY.	PART NO.	TITLE
1	2	8153	CAF - ME-3/8 C X 1/4 M	64	2	115055	WASHER - UPHOLSTERY ROLLER
2	2	9001	PIN SPRING - 3/16 X 1/2	65	2	115056	BEARING - FLANGE-.625 ID SHORT
3	1	9003	PIN SPRING - 1/4 X 1/2	66	2	115072	GUIDE / BEARING
4	8	9014	SCREW - HSSS 8-32 X 1/8 SS	67	2	115080	COVER - BEARING
5	2	9026	SCREW - HSSS 5/16-18 X 1/4 ZP	68	1	115314	TUBE - SLEEVE
6	1	9076	SCREW - SFCHCS 04375-14 X 1 ZP	69	1	115323	FILTER - IN LINE
7	1	9077	SCREW - SFCHCS SL 04375-14 X 1 BLK	70	2	115333	O-RING - .943 X .737 X .103
8	4	9098	SCREW - SHCS 1/4-20 X 1/2 ZP	71	3	115372	DECAL - KEISER LOGO-1 1/4" RED
9	2	9101	SCREW - SHCS 5/16-18 X 1 ZP	72	2	115404	PLUG - HOLE-1 DIA
10	4	9127	SCREW - SHSS 1/2 X 1 ZP	73	2	115420	NEEDLE BEARING B-146
11	1	9152	SCREW - HHCS 1/4-20 X 2 ZP	74	3	115421	THRUST BEARING T-88
12	4	9176	SCREW - HHCS 5/16-18 X 1 ZP	75	18	115423	TIE - 8 IN-PL BLK
13	1	9177	SCREW - HHCS 5/16-18 X 1-3/4 ZP	76	1	115424	SNAP-IN NYLINER
14	6	9181	SCREW - HHCS 5/16-18 X 2 3/4 ZP	77	1	115427	GRIP - 0500 X 2500
15	1	9203	SCREW - HHCS 3/8-16 X 1 1/2 ZP	78	1	115429	PLASTIC TIE - 10" RED
16	1	9206	SCREW - HHCS 3/8-16 X 2 1/4 ZP	79	1	115448	PLACARD-LEG EXT PRO-PRNTD
17	1	9225	NUT - HELN 1/4-20 ZP	80	3	115450	WASHER - FW .88 X .39 X .07 NP
18	7	9226	NUT - HELN 5/16-18 ZP	81	3	115451	SCREW - SBHCS 3/8-16 X 1-1/4 NP
19	7	9227	NUT - HRLN 3/8-16 ZP	82	2	115484	BELT - LEG EXT PRO
20	2	9228	NUT - HELN 3/8-16 ZP	83	2	135055	STEM BUMPER
21	2	9231	NUT - HJN 3/4-10 ZP	84	2	165421	STOP - EA-URETHANE
22	2	9272	SCREW - CRPHTS-TF #6-32 X 1/2 SS	85	1	170891	ASSY - MUFFLER-LONG
23	4	9279	SCREW - SBHTS-TF 5/16-18 X 3/4 ZP	86	2	265055	BEVEL WASHER
24	3	9285	SCREW - CRPHTS 10-24 X 3/4 ZP	87	2	265404	PLASTIC RIVET
25	4	9288	SCREW - CRPHTS TF 10-24 X 1 ZP	88	1	320800	VALVE BLOCK
26	6	9291	SCREW - CRPHTS 8 X 1/2 ZP	89	1	545055	ANCHOR - CABLE PL
27	12	9353	WASHER - ACFT-5/16 ZP	90	1	600881X	DISPLAY BOX - 5 WIN
28	9	9355	WASHER - FW-ACFT-3/8 SS	91	1	605056	DISPLAY BOX - BACK
29	2	9364	WASHER - ITLW 3/4 ZP	92	1	605428	GROUND CLAMP - DISPLAY
30	2	9366	WASHER - ITLW #6 ZP	93	1	953101	TUBING - .375 OD X .062 W-PE BLK
31	4	9389	WASHER - ITLW 5/16 ZP	94	1	953108	TUBING - 1/4 URETHANE BLK
32	2	100903	TANK - 72 IN3	95	1	955300	STRIP - PROTECTOR-4 INCH
33	4	105423	BUMPER - MOLDED GLIDE	96	2	962004	CON - 2MM-2-S
34	1	105443	DECAL - SERIAL NUMBER	97	6	962005	CON - MOD - P-4P-4C
35	2	110830	ASSY - TB VALVE-DIG	98	1	962016	CON - MOD-COUPLER-6-6
36	2	110847	ASSY - EC-2.5 X 7	99	4	962017	CON-MOD-P-6P-6C
37	2	110850	ROLLER CUSHION	100	1	966701	WIRE - CABLE-4-26 GA
38	1	110873	CUSHION - BACK-CURVED	101	1	966702	WIRE - CABLE-6-26GA
39	1	110879	CUSHION - SEAT-LONG	102	3	990812	KEY - DATA-CS
40	1	110897	ASSY - QD-MALE	103	1	990818	PROCESSOR BOX - A250-DBL
41	1	110909	SEAT BACK PIVOT	104	2	995000	COLLAR - GRIP
42	1	110910	EX ARM - L	105	2	995001	CAP - GRIP W HOLE
43	1	110911	EX ARM - R	106	2	995060	PLUG - TUBE-1500 OD
44	1	110912	SEAT BACK	107	2	995061	PLUG - TUBE-1000 X 1500
45	1	110916	PAWL	108	2	995160	GRIP - MOLDED
46	1	110919	SEAT FR PIVOT	109	1	995300	DECAL - TB-PLUS
47	1	110953	LEVER ARM - L	110	1	995301	DECAL - TB-MINUS
48	1	110954	LEVER ARM - R	111	1	995308	DECAL - SEAT-POWER
49	1	110955	FRAME - MAIN-LEG EXT PRO	112	1	995324	DECAL - MADE IN THE USA
50	1	110956	WELDT - DISPLAY MT	113	1	995418	BAG - 4 X 6 X 4MIL-ZIP LOCK
51	1	112180	SHAFT - PUSH ARM	114	1	995615	PLACARD - ENG-POWER-BLK
52	1	112181	PAWL HANDLE	115	1	995616	PLACARD - ENG-KEY-RED
53	1	112182	SEAT BACK PIVOT SFT				
54	1	112221	PIVOT SHAFT				
55	4	112242	CLAMP DISC				
56	4	113040	SHOULDER SLEEVE - 1/2 X 1/2				
57	2	115000	BUSHING - TANK				
58	2	115005	CLEVIS - CYLINDER-2-1/2				
59	2	115006	3/4 END CAP				
60	1	115010	RACK - MACHINED				
61	8	115051	BEARING - FLANGE-.5 ID				
62	10	115052	BEARING - FLANGE-.625 ID				
63	2	115054	PLUG - 2 IN SQ-KEISER				

1133XP

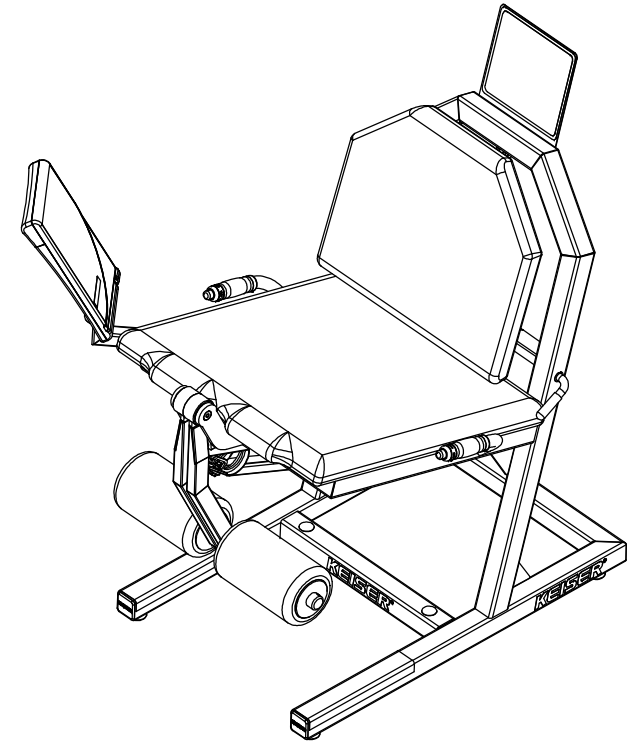



2470 South Cherry Ave. Phone: (559) 256-8000
Fresno, CA, USA 93706-6004 Fax: (559) 256-8100

THE INFORMATION DISCLOSED HEREIN WAS ORIGINATED BY AND IS THE PROPERTY OF KEISER CORP. AND ALL PATENT, PROPRIETARY, DESIGN, USE, SALE, MANUFACTURING, AND REPRODUCTION RIGHTS THERE TO ARE RESERVED BY KEISER CORP.

DIMENSIONS ARE IN INCHES
DIMENSIONS IN [] ARE MILLIMETERS
BREAK SHARP EDGES .005-.015 [10-.40]
MACHINED SURFACE FINISH IS
63 MICRONS [1.6 MICROMETERS]
DO NOT SCALE DRAWING

DRAWN BY: JPR	DATE DRAWN: 10/8/18	CHECKED BY: DEM	DATE CHECKED: 12/21/18
MATERIAL:			
RAW MAT:			

TITLE: A-300 - LEG EXT PRO-PWR	SHEET 2 OF 5	SCALE: 1:10	DRAWING SIZE: B	PART#: 1133XP
--------------------------------	--------------	-------------	-----------------	---------------

REV	DESCRIPTION	BY	CHKD	DATE
B	3648 RISW	JPR	DEM	10/5/20

X:\drawings\REVISION11_LEG_EXTENSION\ PRINTED ON: 10/6/2020 SW2006 V5.1